

DETAIL 1

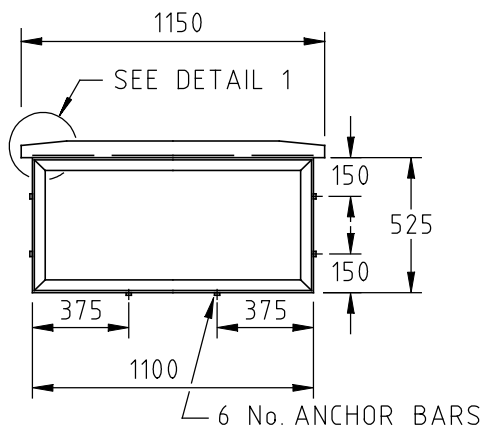

GRATE FRAME

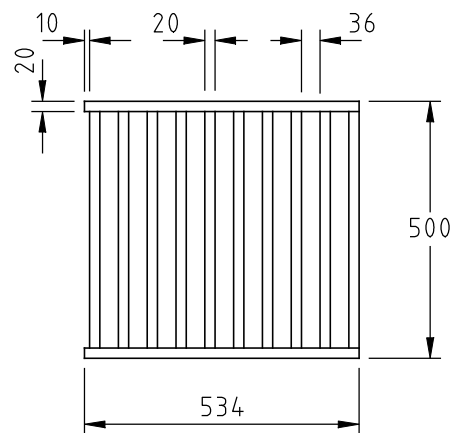

GRATE

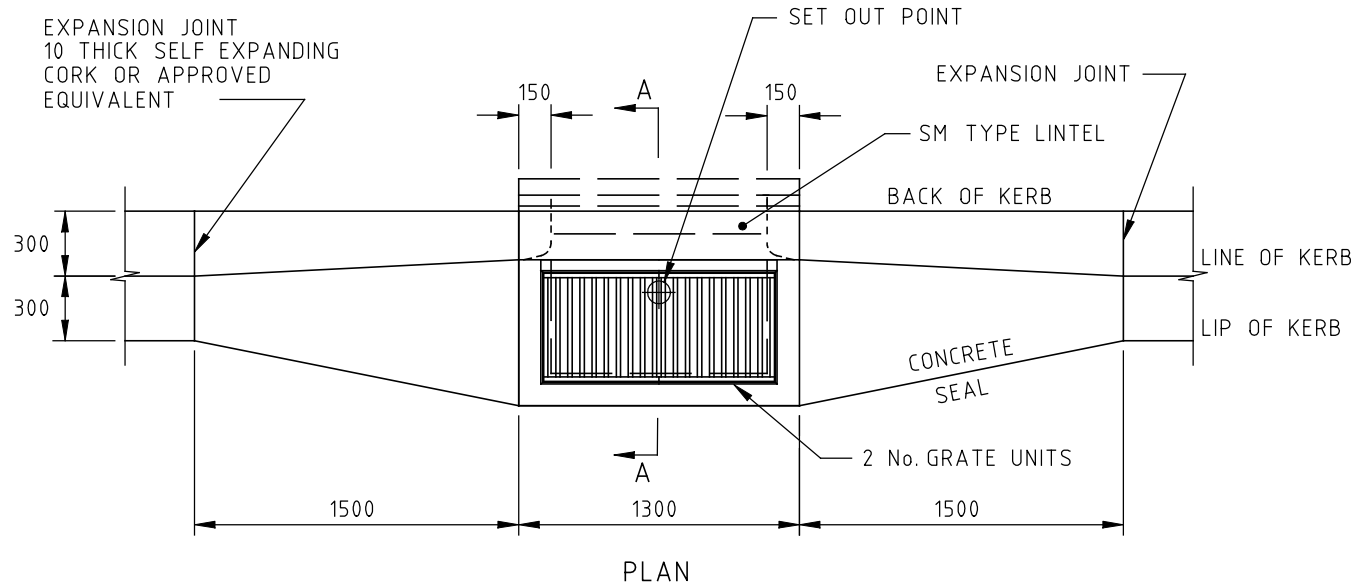

PLAN

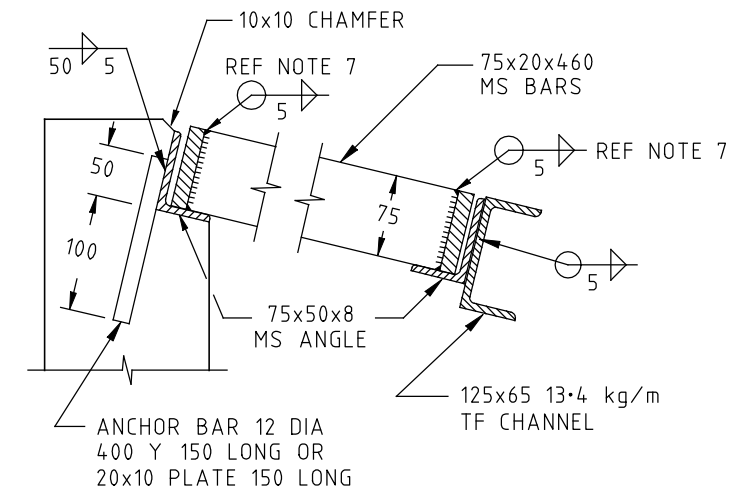

SECTION THROUGH GRATE

NOTES:

1. HAUNCHING MAY BE REQUIRED FOR PIPES OVER 450 DIA, REFER TO PIT SCHEDULE FOR SIZES OF SPECIFIC PITS. PITS WITH HAUNCHING IN TWO DIRECTIONS REQUIRE SPECIAL STRUCTURAL DESIGN.
2. PIT REINFORCEMENT - F92. LAPS TO BE 300 MINIMUM. CLEAR COVER TO BE 50 MINIMUM. CORNER RETURN REINFORCEMENT MAY BE FABRIC OR EQUIVALENT BARS. BARS GRADE 400Y & FABRICS TO COMPLY WITH AS/NZS 4671 CONCRETE SHALL BE NORMAL-CLASS N32 STANDARD STRENGTH GRADE OR HIGHER COMPLYING WITH THE REQUIREMENTS OF AS 1379. EXPOSURE CLASSIFICATIONS UP TO AND INCLUDING B1.
3. PITS DEEPER THAN 1000 SHALL BE FITTED WITH STEP IRONS. REF. SD 1041.
4. CONCRETE LINTEL IS REQUIRED TO SUPPORT A TEST LOAD OF 100 kN IN ACCORDANCE WITH VICROADS' "INTERIM TEST METHOD FOR TEST LOADING PIT COVERS, LINTELS AND LIDS."
5. PRECAST UNITS MAY BE CONSTRUCTED TO THE MANUFACTURER'S DETAILS. THE DESIGN SHALL COMPLY WITH THE AS 5100 BRIDGE DESIGN AND THE FOLLOWING ADDITIONAL REQUIREMENTS :
 - COMBINED FACTORED LATERAL PRESSURE AT ANY POINT AT THE ULTIMATE LIMIT STATE SHALL BE NOT LESS THAN 25 kPa.
 - ADEQUATE DRAINAGE SHALL BE PROVIDED TO PIT WALLS TO AVOID HYDROSTATIC PRESSURE.
 - VERTICAL LOAD 210 kN APPLIED ANYWHERE ON PIT.
 - MINIMUM REINFORCEMENT AREA SHALL BE 150 mm²/m.
 - CONCRETE SHALL BE NORMAL-CLASS N32 STANDARD STRENGTH GRADE OR HIGHER COMPLYING WITH THE REQUIREMENTS OF AS 1379. EXPOSURE CLASSIFICATIONS UP TO AND INCLUDING B1.
6. GRATE FRAME SHALL BE CONSTRUCTED FROM 75x50x8 MS ANGLE. EACH CORNER SHALL BE CHAMFERED ON UNDERSIDE OF HORIZONTAL LEG AND ON INSIDE OF VERTICAL LEG BEFORE WELDING WITH SINGLE V BUTT WELD. FRAME TO BE WELDED TO 125x65 13.4kg/m TF CHANNEL.
7. GRATE UNITS SHALL BE MADE FROM 75x20x460 MS BARS. THE TOP AND BOTTOM EDGES OF THE BAR ENDS SHALL BE CHAMFERED 5mmx5mm BEFORE CONTINUOUSLY WELDING ALL AROUND AND GROUND FLUSH BEFORE GALVANIZING.
8. BOTH GRATE AND GRATE FRAME SHALL BE HOT DIP GALVANIZED TO AS 1650 UNLESS SPECIFIED OTHERWISE.

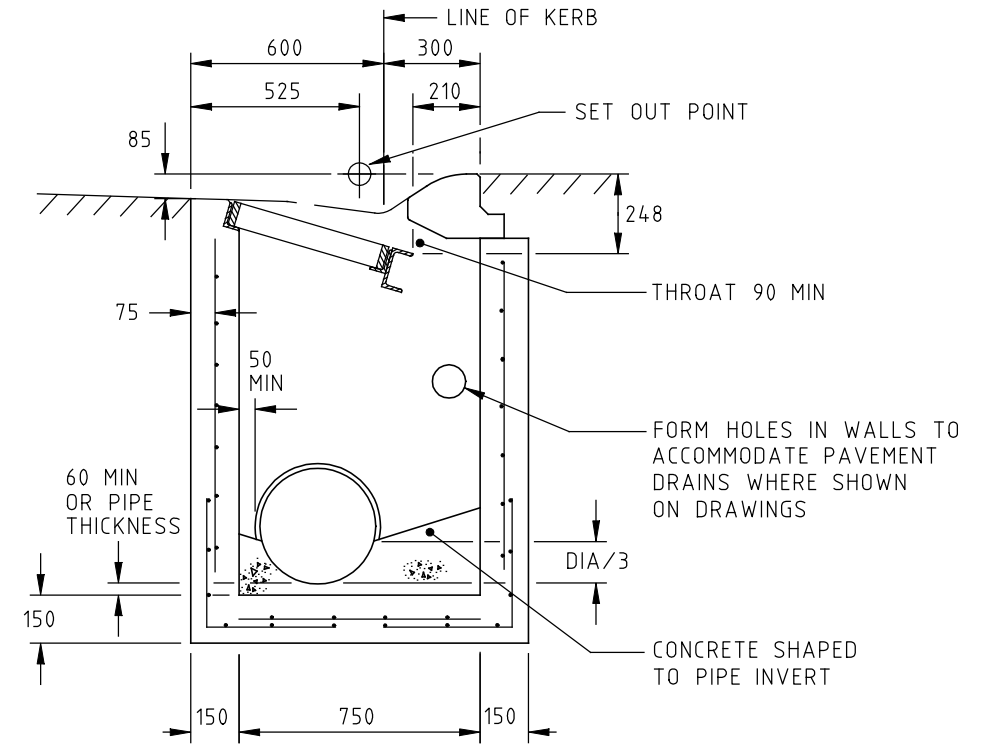

SECTION A-A

E	J.K.	1/7/05	AS 1302 & 1304 SUPERSEDED BY AS/NZS 4671. AUSTRALIAN BRIDGE CODE 1996 SUPERSEDED BY AS 5100 BRIDGE CODE
D	J.B.	SEPT'99	CROWN LINES REMOVED
C	J.C.	1/2/98	AMENDMENT TO NOTES 2 & 5, CONCRETE STRENGTH GRADES.
B	J.C.	1/7/95	STRENGTH OF ANCHOR BAR AMENDED.
A	J.C.	1/9/94	SET OUT POINT, INVERT DEPTH, GENERAL NOTE 6, NOTES 2, 4, 5, 7, 8 & 9, SECTION A-A, CHANNEL DETAIL
ISSUE	APP'D	DATE	AMENDMENT

GENERAL NOTES	
1. STANDARD PITS DIMENSIONING & SETTING OUT DETAILS	SD 1001
2. UNHAUNCHED PITS	SD 1011
3. HAUNCHED PITS	SD 1021
4. STEP IRONS	SD 1041
5. LINTELS	SD 1061
6. ALL DIMENSIONS ARE IN MILLIMETRES	

DESIGNED	PRINCIPAL ROAD DESIGN ENGINEER
APPROVED	23.9.94 <i>J. Cunningham</i>
CATALOG PROJECT FILENAME	PRED sddgnnew sd-1321e.dgn

vikroads design
ENGINEERING & TECHNOLOGY CONSULTANTS

3 PROSPECT HILL ROAD, CAMBERWELL, VICTORIA, 3124
PHONE NO. (03) 9811 8355
FAX NO. (03) 9811 8329

SCALE HOR OF METRES VER NOT TO SCALE

STANDARD DRAWING GRATED SIDE ENTRY PIT (SM KERB) ONE METRE INLET				
FILE NO.	CONTRACT NO.	SHEET NO.	DRAWING NO.	ISSUE
			SD 1321	E

sd-1321e.dgn 30/03/2006 3:07:22 PM