

Eco-Weaved "V" G&F: 900x450mm P/S, Heavy Duty (Class D)

# SG-H-MSG-EWV9045

| Feature                                   | Value       | Notes                      |
|---|-------------|----------------------------|
| Overall Grate Size (mm)                   | 1000x453x50 | Does not include "V" drop. |
| Overall Frame Size (mm)                   | 1020x513x55 | Does not include "V" drop. |
| Grate Weight (kg)                         | 47.0        |                            |
| Frame Weight (kg)                         | 13.0        |                            |
| Total Product Weight (kg)                 | 60.0        |                            |
| Grate Open Surface Area (m <sup>2</sup> ) | 0.4 (78%)   |                            |
| Class Rating (AS3996 - 2006)              | D           |                            |
| Ultimate Limit State Load (kN)            | 210         |                            |
| Servicability Limit State Load (kN)       | 140         |                            |
| Nominal Wheel Loading (kg)                | 8000        |                            |
| Product Finish                            | Galvanised  |                            |

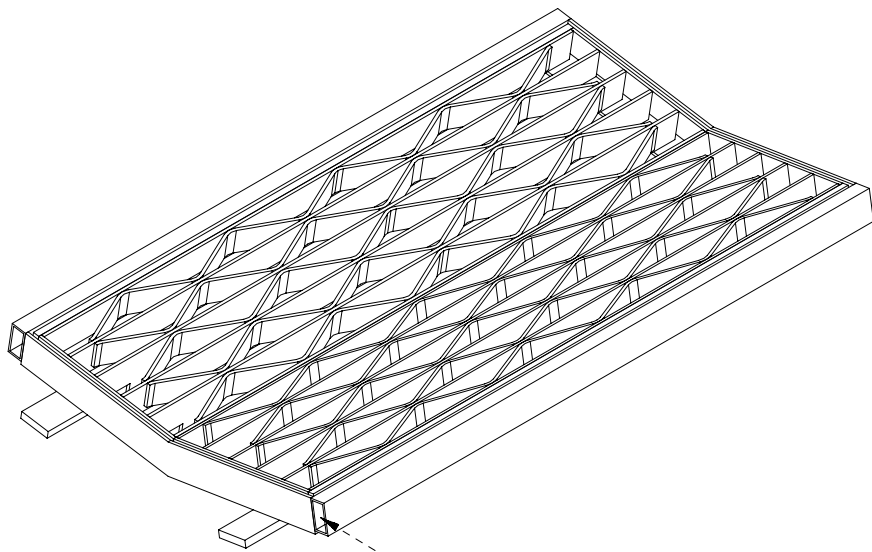

50x25x3mm RHS edge, with ends left open.

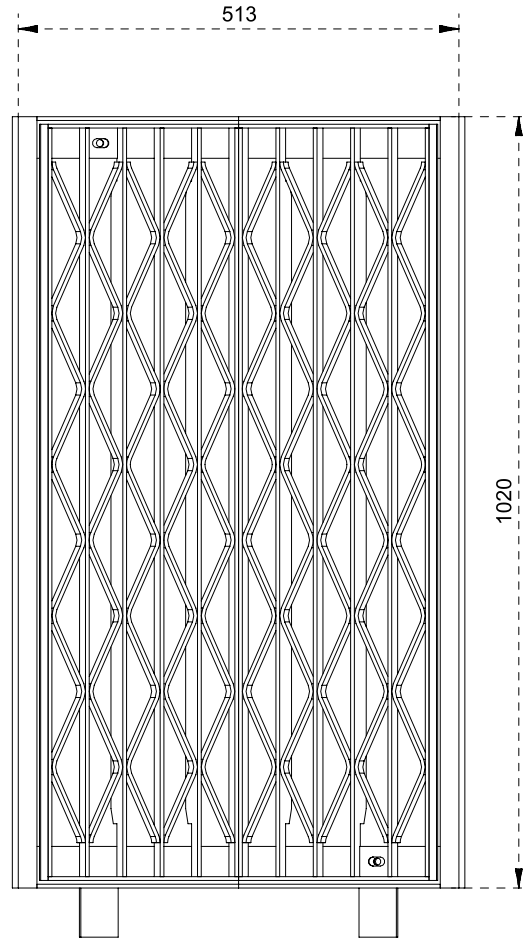
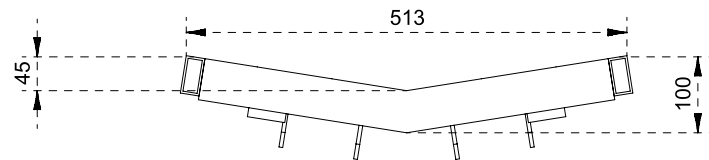

ROAD SAFETY GRATING  
13 HEALEY RD  
DANDENONG SOUTH, VIC 3175  
  
PH: (03) 9238 5888  
FAX: (03) 9238 5800  
EMAIL: sales@grating.com.au  
WEB: www.grating.com.au

| Attachments |
|-------------|
| a           |
| b           |
| c           |
| d           |
| e           |
| f           |
| g           |

**Disclaimer**  
Drawings are provided in good faith and for use by the intended recipient only. Drawings remain the property of Straighmark Nominees Pty Ltd T/A Road Safety Grating (R&S). If this drawing has been received in error, or you are not the intended recipient, please delete it immediately and notify Road Safety Grating.  
Drawings are not to be transferred to a third party without written consent from Road Safety Grating. Road Safety Grating accepts no liability for misuse of, or reliance on, this drawing. If in doubt about any details on the drawing, please contact Road Safety Grating.

| Sheet Information |                        |
|-------------------|------------------------|
| No.               | Description            |
| 1                 | Grate & Frame Overview |
| 2                 | Grate & Frame Details  |
| 3                 |                        |
| 4                 |                        |
| 5                 |                        |
| 6                 |                        |

| Sheet No.                               |                    | 1 of 2           |        |
|---|--------------------|------------------|--------|
| Scale                                   |                    |                  |        |
| AS NOTED, ONLY VALID WHEN PRINTED ON A4 |                    |                  |        |
| QTY                                     | Part File Name     | Part Weight (kg) | Sheets |
| 1                                       | sg-h-msg-ewv9045g1 | 47.0             | 1, 2   |
| 1                                       | sg-h-msg-ewv9045f1 | 13.0             | 1, 2   |

| Title  |                     |                   |                  |
|--|---------------------|-------------------|------------------|
| Eco-Weaved "V" G&F: 900x450mm P/S, Heavy Duty (Class D), Bolt Down |                     |                   |                  |
| Subtitle   |                     | Galvanised        |                  |
| Class Rating (AS3996 - 2006)                                       | D                   | Product Code      | sg-h-msg-ewv9045 |
| Drawing No.  | ps_sg-h-msg-ewv4545 | Primary Material  | Galvanised MS    |
| Version No.  | 1.0                 | Previous Versions | Nil              |
| Designed   | N/A                 | Drawn             | TH               |
| Date   | N/A                 | Date              | 30/05/2016       |
| Approved   | CT                  | Date              | 30/05/2016       |

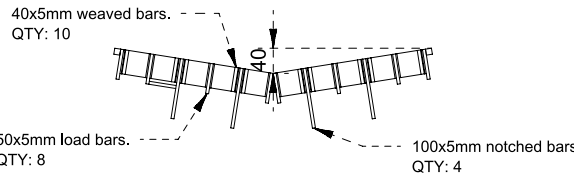
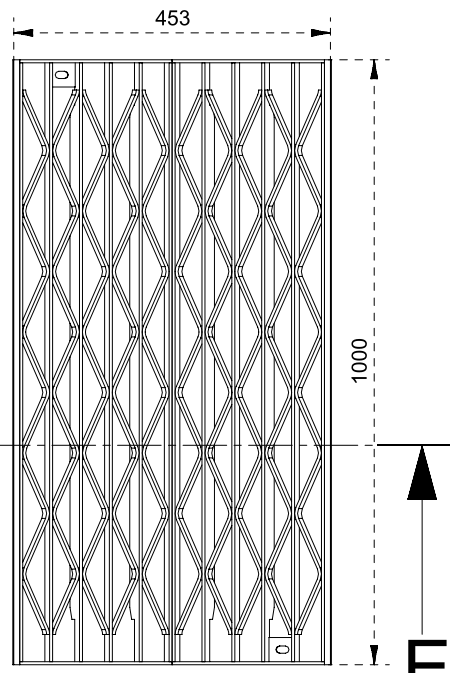

SECTION E-E

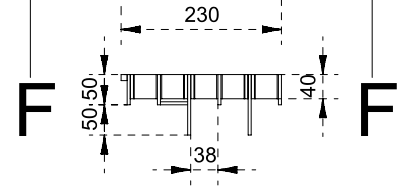
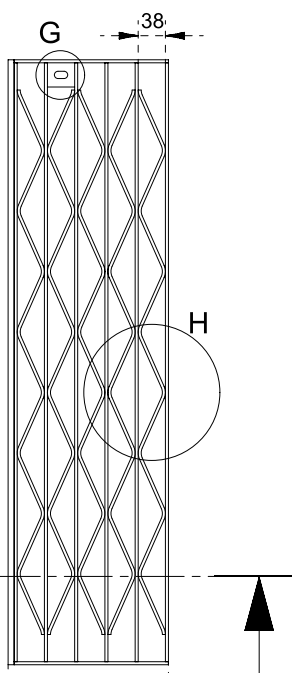

SECTION F-F

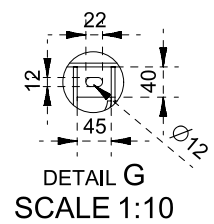
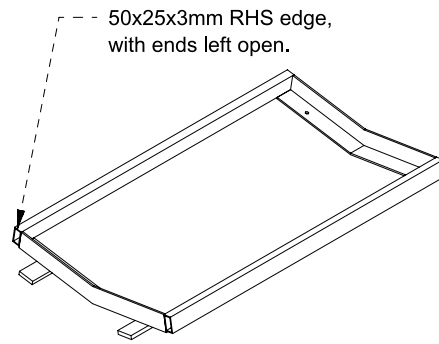

DETAIL G  
SCALE 1:10

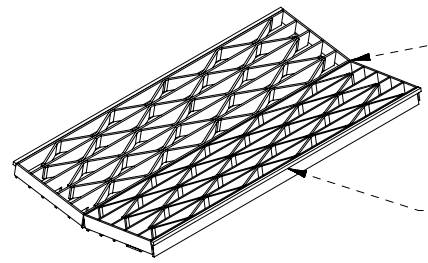
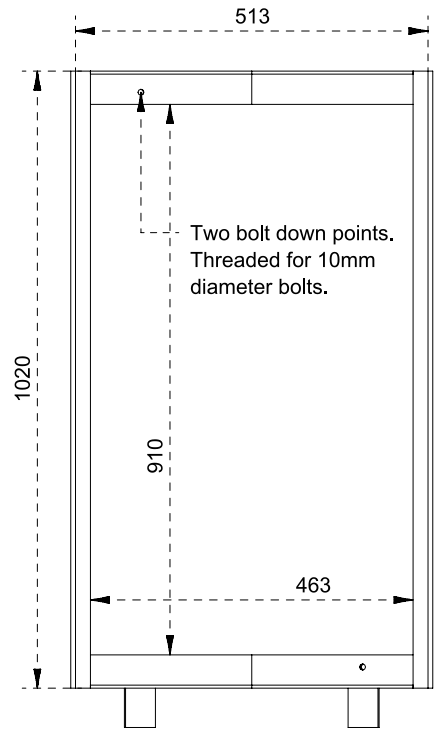

Two grates welded together along "V" line.

10x10mm flat along both edges of grate.

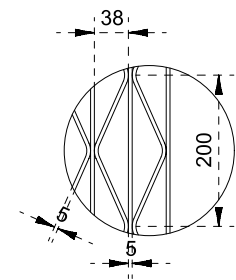

DETAIL H  
SCALE 1:10

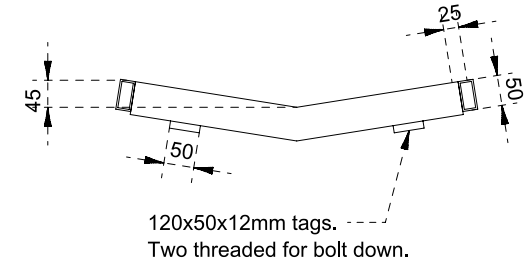

120x50x12mm tags. Two threaded for bolt down.

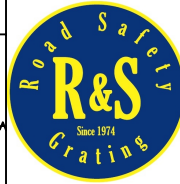

ROAD SAFETY GRATING  
13 HEALEY RD  
DANDENONG SOUTH, VIC 3175  
PH: (03) 9238 5888  
FAX: (03) 9238 5800  
EMAIL: sales@grating.com.au  
WEB: www.grating.com.au

| Attachments |  |
|-------------|--|
| a           |  |
| b           |  |
| c           |  |
| d           |  |
| e           |  |
| f           |  |
| g           |  |

**Disclaimer**  
Drawings are provided in good faith and for use by the intended recipient only. Drawings remain the property of Straighmark Nominees Pty Ltd T/A Road Safety Grating (R&S). If this drawing has been received in error, or you are not the intended recipient, please delete it immediately and notify Road Safety Grating. Drawings are not to be transferred to a third party without written consent from Road Safety Grating. Road Safety Grating accepts no liability for misuse of, or reliance on, this drawing. If in doubt about any details on the drawing, please contact Road Safety Grating.

| Sheet Information |                        |
|-------------------|------------------------|
| No.               | Description            |
| 1                 | Grate & Frame Overview |
| 2                 | Grate & Frame Details  |
| 3                 |                        |
| 4                 |                        |
| 5                 |                        |
| 6                 |                        |

| Sheet No.                               |                    | 2 of 2           |        |
|---|--------------------|------------------|--------|
| Scale                                   |                    |                  |        |
| AS NOTED, ONLY VALID WHEN PRINTED ON A4 |                    |                  |        |
| QTY                                     | Part File Name     | Part Weight (kg) | Sheets |
| 1                                       | sg-h-msg-ewv9045g1 | 47.0             | 1, 2   |
| 1                                       | sg-h-msg-ewv9045f1 | 13.0             | 1, 2   |

| Title  |                     |                   |                  |
|--|---------------------|-------------------|------------------|
| Eco-Weaved "V" G&F: 900x450mm P/S, Heavy Duty (Class D), Bolt Down |                     |                   |                  |
| Subtitle   |                     | Galvanised        |                  |
| Class Rating (AS3996 - 2006)                                       | D                   | Product Code      | sg-h-msg-ewv9045 |
| Drawing No.  | ps_sg-h-msg-ewv4545 | Primary Material  | Galvanised MS    |
| Version No.  | 1.0                 | Previous Versions | Nil              |
| Designed   | N/A                 | Drawn             | TH               |
| Date   | N/A                 | Date              | 30/05/2016       |
| Approved   | CT                  | Date              | 30/05/2016       |